

ULTRA-RAPID FUSE

JOONGWON RAPID FUSE

300V 半導体保護用限流ヒューズ JRS30型
600V JRS60型

300V CURRENT LIMITING FUSES FOR PROTECTING SEMICONDUCTORS TYPE JRS30
600V TYPE JRS60

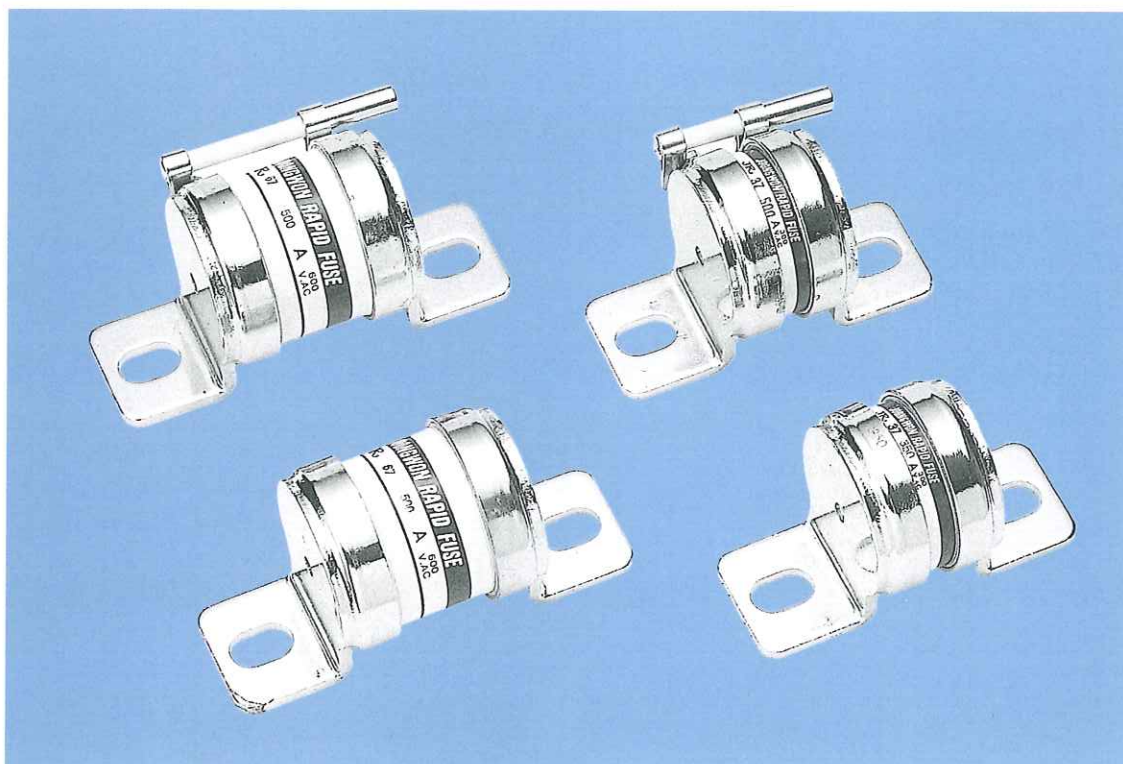

中原電機株式会社
JOONGWON ELECTRIC CORPORATION

高性能、大遮断容量を誇る半導体保護用高速限流ヒューズ

HIGH SPEED CURRENT LIMITING FUSES FOR PROTECTING SEMICONDUCTORS WITH SMALL OPERATING I²T AND LARGE BREAKING CAPACITY.

●まえがき

本ヒューズエレメントは、従来のエレメント製作の常識を破る革新的な製法で量産されるもので、溶断特性、遮断特性及び機械的強度など大幅に改良された新商品です。なお本品はヒューズ規定 IEC60269-4 (2009.5) 及びJEM1383 (1979) に準じて試験検証してあります。

また、RoHS指令にも適合しています。

●FOREWORD

This fuse link is manufactured on the basis of mass production by an innovative manufacturing method that has made a breakthrough in the common sense of conventional manufacture of fuse element. The new product has been improved extensively as to pre - arcing time - current characteristic, breaking capacity and mechanical strength.

Also this product was tested and verified in compliance correspondently to Fuse Rules IEC 60269-4 (2009.5) and JEM 1383 (1979). And, it complies with applicable requirements of the European RoHS Directive 2002/95/EC and associated Decisions amended by Commission.

JRS3 - - - 型および JRS3 - - - I-S 型
AND

■定格および性能 RATINGS AND PERFORMANCE

型式 Type			定格電流 Rated Current A	I ² t値 I ² t Value (A ² s)		電力損失 Power Dissipation W	直流回路への適用 Application for DC Circuit			
表示器なし Without Indicator	表示器つき With Indicator	表示器 マイクロスイッチつき With Indicator and Micro Switch		溶断 I ² t Pre- arcing I ² t	動作 I ² t Operating I ² t		電圧 Voltage	時定数 Time Constant	短絡電流 Shorted Circuit Current	
				at 250V	at 300V					
JRS31-10	JRS31-10I	JRS31-10IS	10	1	4	4	250V 400V	47.5ms 10ms	20kA 20kA	
JRS31-20	JRS31-20I	JRS31-20IS	20	6	40	50				4
JRS31-30	JRS31-30I	JRS31-30IS	30	10	90	110				7
JRS31-40	JRS31-40I	JRS31-40IS	40	25	220	270				8
JRS31-50	JRS31-50I	JRS31-50IS	50	50	390	480				9
JRS31-60	JRS31-60I	JRS31-60IS	60	95	640	790				9
JRS31-75	JRS31-75I	JRS31-75IS	75	300	1400	1800				10
JRS32B-60	JRS32B-60I	JRS32B-60IS	60	80	550	680				11
JRS32B-80	JRS32B-80I	JRS32B-80IS	80	200	1100	1400				14
JRS32B-100	JRS32B-100I	JRS32B-100IS	100	360	2100	2700				16
JRS32B-120	JRS32B-120I	JRS32B-120IS	120	560	3200	3900				17
JRS33-90	JRS33-90I	JRS33-90IS	90	320	1900	2400				13
JRS33-120	JRS33-120I	JRS33-120IS	120	560	3000	3700				16
JRS33-150	JRS33-150I	JRS33-150IS	150	740	4200	5200				23
JRS33-180	JRS33-180I	JRS33-180IS	180	1400	5700	7100				28
JRS36-150	JRS36-150I	JRS36-150IS	150	800	3500	4400				25
JRS36-200	JRS36-200I	JRS36-200IS	200	2000	8700	10000				26
JRS36-250	JRS36-250I	JRS36-250IS	250	4200	16000	20000				27
JRS36-300	JRS36-300I	JRS36-300IS	300	6800	29000	35000				37
JRS37-350	JRS37-350I	JRS37-350IS	350	9000	50000	60000				36
JRS37-400	JRS37-400I	JRS37-400IS	400	14000	73000	90000	40			
JRS37-450	JRS37-450I	JRS37-450IS	450	20000	110000	130000	46			
JRS37-500	JRS37-500I	JRS37-500IS	500	32000	160000	190000	54			
JRS37-600	JRS37-600I	JRS37-600IS	600	40000	184000	220000	50			
JRS37-700	JRS37-700I	JRS37-700IS	700	60000	280000	340000	60			
JRS37-800	JRS37-800I	JRS37-800IS	800	88000	400000	480000	60			
JRS37-900	JRS37-900I	JRS37-900IS	900	132000	600000	750000	70			

定格電圧：300VAC (r.m.s.)
動作過電圧：800V以下
遮断容量：100kA at AC300V

Rated Voltage : 300VAC (r.m.s.)
Switching Voltage : Less Than 800V
Breaking Capacity : 100kA at AC300V

高性能、大遮断容量を誇る半導体保護用高速限流ヒューズ

HIGH SPEED CURRENT LIMITING FUSES FOR PROTECTING SEMICONDUCTORS WITH SMALL OPERATING I²T AND LARGE BREAKING CAPACITY.

●特長

- ①大きな遮断容量とすぐれた限流遮断
- ②非常に小さな動作I²tと低い動作過電圧で、半導体保護に最適
- ③特性にバラツキが少なく経年変化がない
- ④小型軽量であるので装置が小さくなる
- ⑤直流電流も遮断可能

●SPECIAL FEATURES

- (1) Large breaking capacity and current limiting interruption.
- (2) Most suited to the protection of semiconductors because of the very small operating I²t and low switching voltage.
- (3) There is no secular variance providing little variance in characteristics.
- (4) Because of small size and light weight, the device becomes small.
- (5) Interruption is possible also for DC current.

JRS6 - - - 型および JRS6 - - - I-S 型
AND

■定格および性能 RATINGS AND PERFORMANCE

型式 Type			定格電流 Rated Current A	I ² t値 I ² t Value (A ² s)		電力損失 Power Dissipation W	直流回路への適用 Application for DC Circuit			
表示器なし Without Indicator	表示器つき With Indicator	表示器 マイクロスイッチつき With Indicator and Micro Switch		溶断 I ² t Pre- arcing I ² t	動作 I ² t Operating I ² t		電圧 Voltage	時定数 Time Constant	短絡電流 Shorted Circuit Current	
				at 440V	at 600V					
JRS61-10	JRS61-10I	JRS61-10IS	10	2	15	20	320V 600V	50ms 11ms	20kA 20kA	
JRS61-20	JRS61-20I	JRS61-20IS	20	12	64	90				11.5
JRS61-30	JRS61-30I	JRS61-30IS	30	34	200	290				12.5
JRS61-40	JRS61-40I	JRS61-40IS	40	72	400	560				15.5
JRS61-50	JRS61-50I	JRS61-50IS	50	125	760	1100				16
JRS61-60	JRS61-60I	JRS61-60IS	60	200	1350	1800				17.5
JRS61-75	JRS61-75I	JRS61-75IS	75	600	3800	5300				15
JRS62-60	JRS62-60I	JRS62-60IS	60	150	950	1300				18.5
JRS62-80	JRS62-80I	JRS62-80IS	80	440	2300	3200				20.5
JRS62-100	JRS62-100I	JRS62-100IS	100	760	4700	6500				23
JRS62-120	JRS62-120I	JRS62-120IS	120	1200	7700	10500				24
JRS63-90	JRS63-90I	JRS63-90IS	90	580	2800	4000				23
JRS63-120	JRS63-120I	JRS63-120IS	120	920	5700	8000				27
JRS63-150	JRS63-150I	JRS63-150IS	150	2100	12500	18000				29.5
JRS63-180	JRS63-180I	JRS63-180IS	180	3400	17500	25000				32
JRS66-150	JRS66-150I	JRS66-150IS	150	1600	8000	11500				38
JRS66-200	JRS66-200I	JRS66-200IS	200	4400	21500	30000				38
JRS66-250	JRS66-250I	JRS66-250IS	250	7800	38000	54000				40
JRS66-300	JRS66-300I	JRS66-300IS	300	12500	57000	80000				50
JRS67-350	JRS67-350I	JRS67-350IS	350	32000	110000	150000				50
JRS67-400	JRS67-400I	JRS67-400IS	400	48000	160000	220000	53			
JRS67-450	JRS67-450I	JRS67-450IS	450	72000	230000	320000	57			
JRS67-500	JRS67-500I	JRS67-500IS	500	90000	300000	420000	60			
JRS67-600	JRS67-600I	JRS67-600IS	600	132000	420000	560000	68			
JRS67-700	JRS67-700I	JRS67-700IS	700	216000	530000	760000	80			
JRS67-800	JRS67-800I	JRS67-800IS	800	312000	900000	1260000	85			
JRS67-900	JRS67-900I	JRS67-900IS	900	392000	1100000	1520000	85			

定格電圧：600VAC (r.m.s.)
動作過電圧：1350V以下
遮断容量：100kA at AC600V

Rated Voltage : 600VAC (r.m.s.)
Switching Voltage : Less Than 1350V
Breaking Capacity : 100kA at AC600V

JRS31 JRS32

溶断時間—電流特性

Pre-arcing Time—Current Characteristics

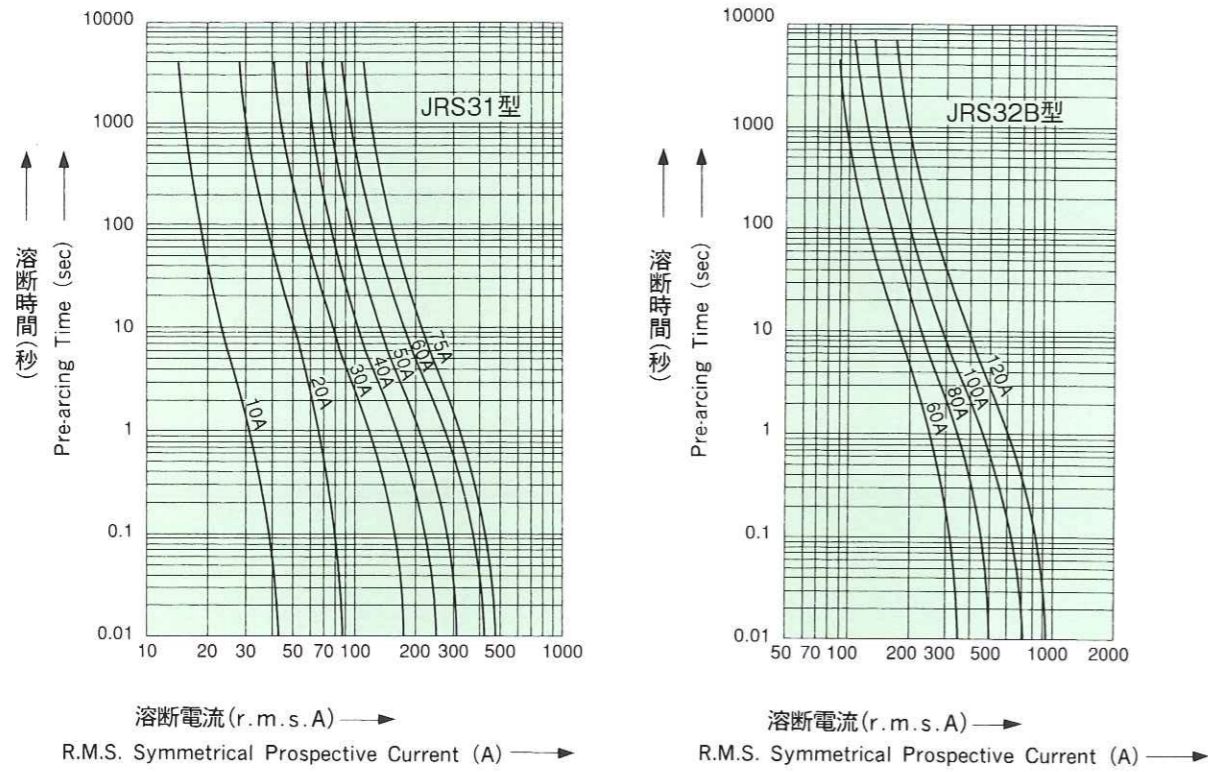

JRS33 JRS36

溶断時間—電流特性

Pre-arcing Time—Current Characteristics

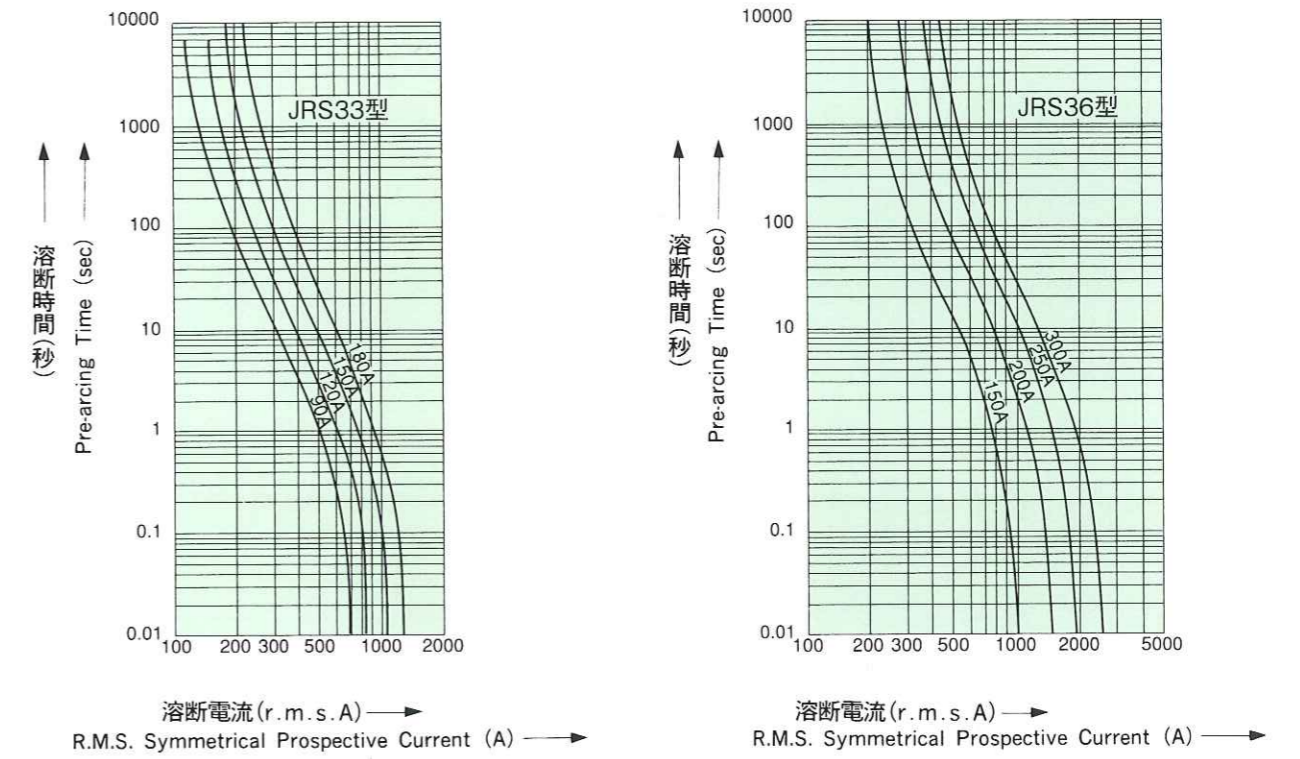

限流特性

Cut-off Current Characteristics

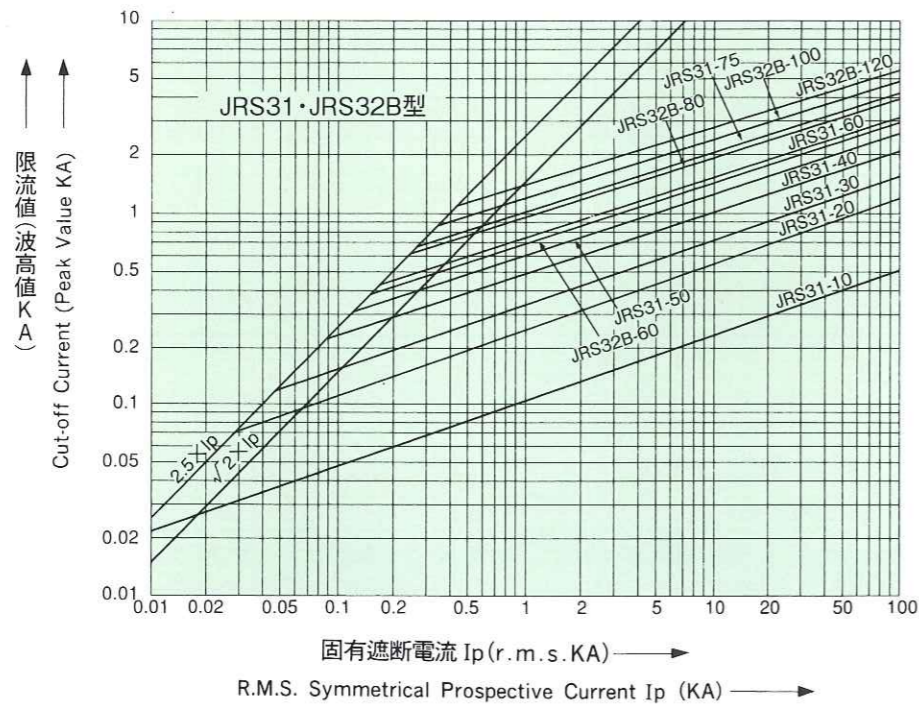

限流特性

Cut-off Current Characteristics

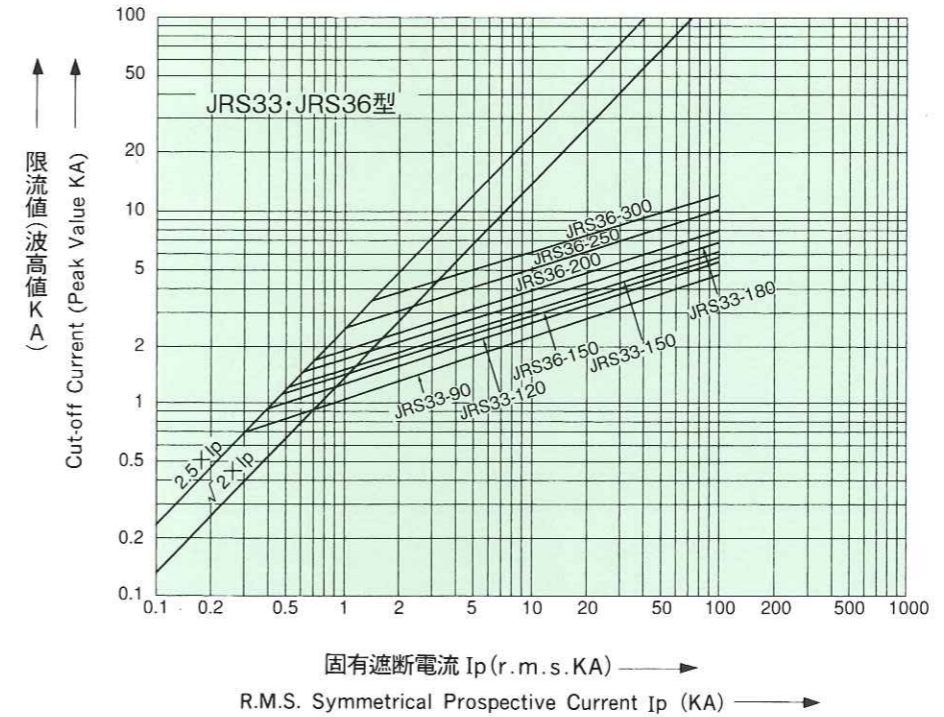

JRS37

溶断時間—電流特性

Pre-arcing Time—Current Characteristics

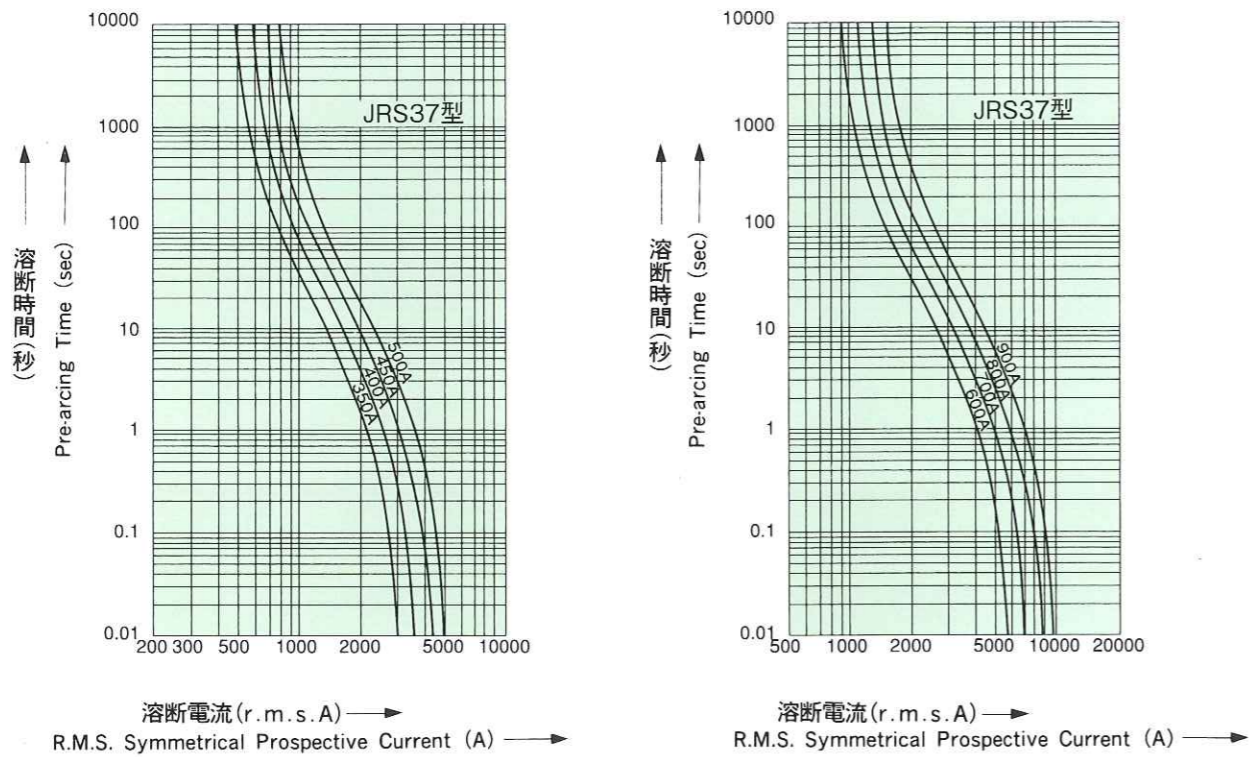

JRS61 JRS62

溶断時間—電流特性

Pre-arcing Time—Current Characteristics

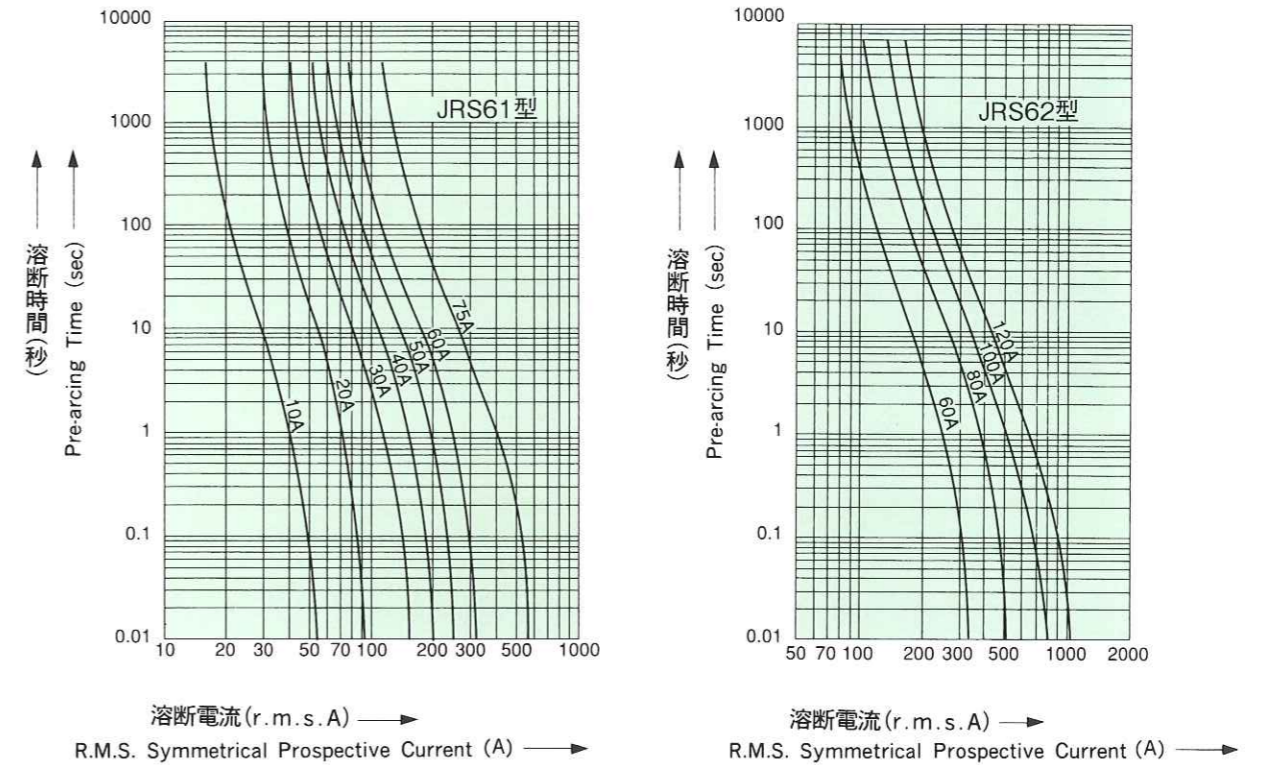

限流特性

Cut-off Current Characteristics

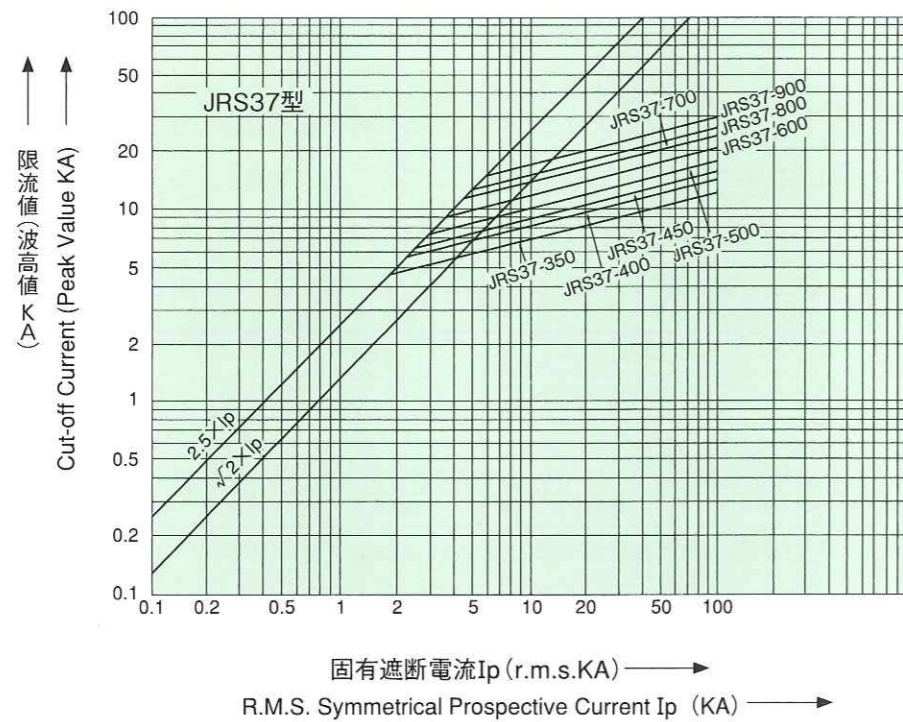

限流特性

Cut-off Current Characteristics

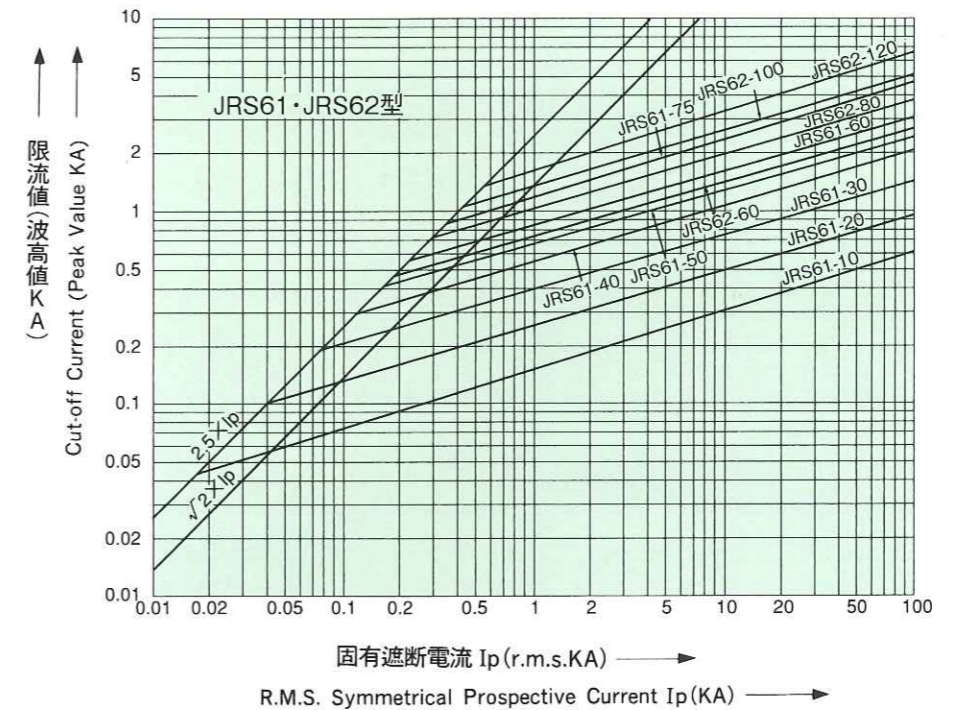

JRS63 JRS66

溶断時間—電流特性

Pre-arcing Time—Current Characteristics

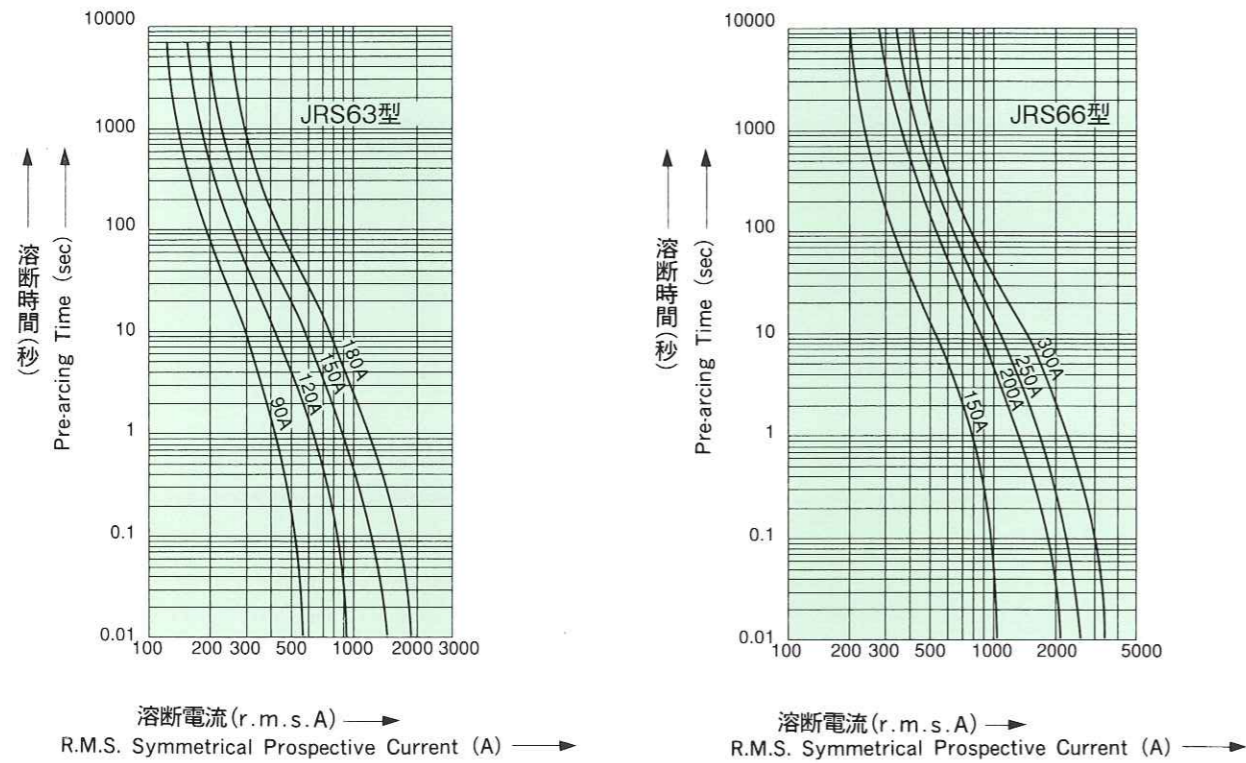

JRS67

溶断時間—電流特性

Pre-arcing Time—Current Characteristics

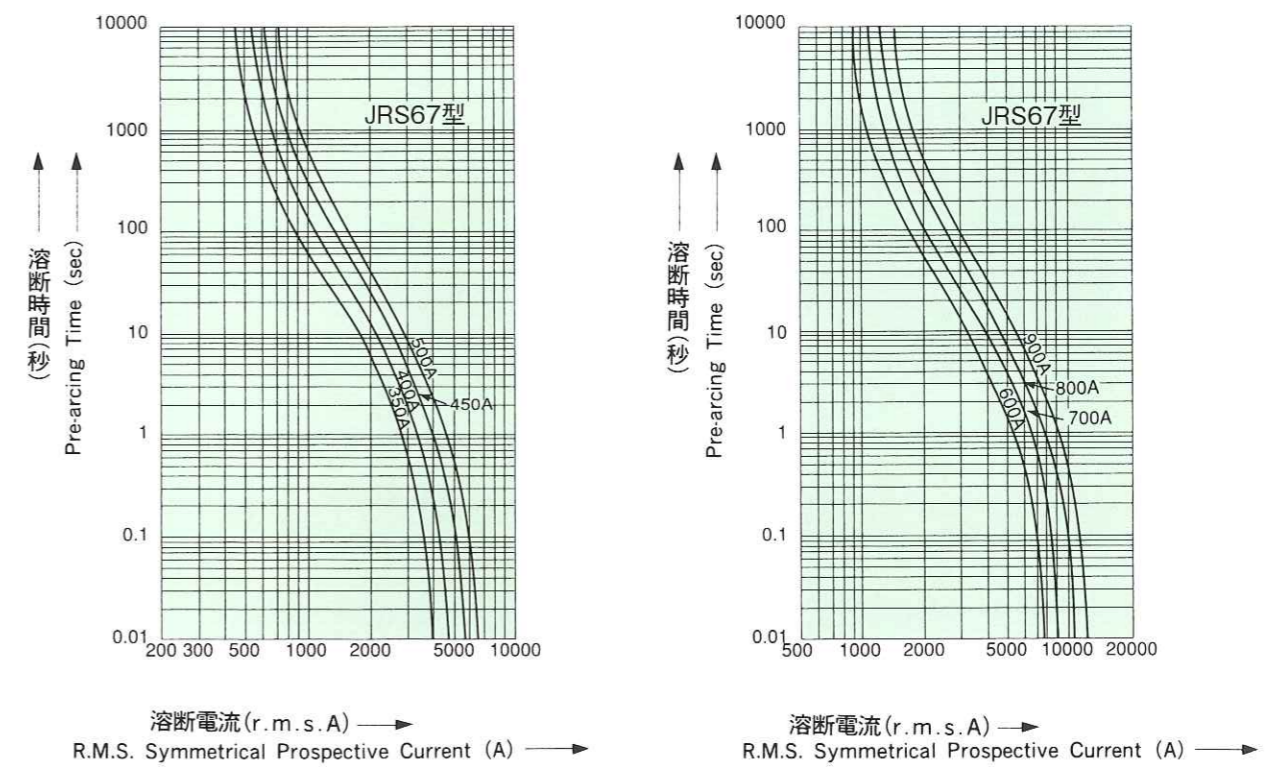

限流特性

Cut-off Current Characteristics

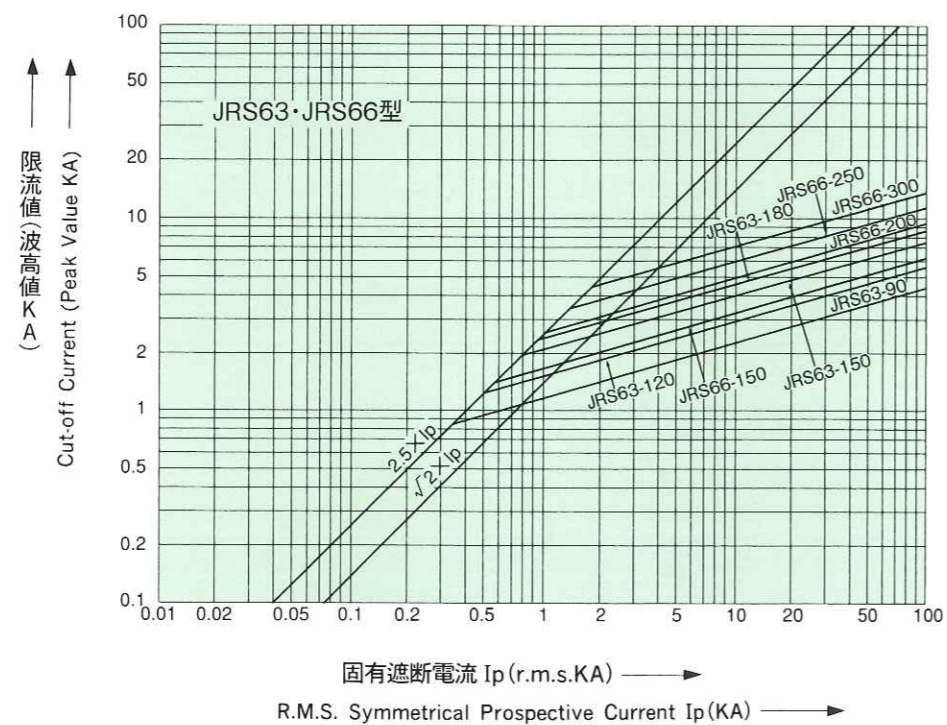

限流特性

Cut-off Current Characteristics

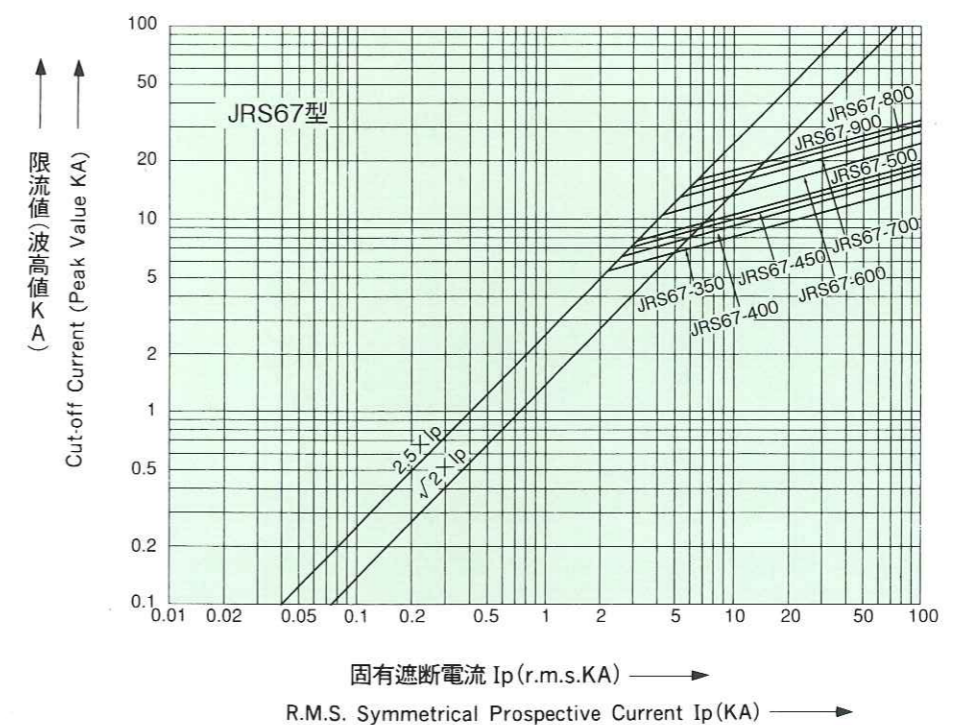

JRS30/60型ヒューズ外形寸法 (表示器なし)

Type JRS30/60 Fuse Outline Dimensions (Without Indicator)

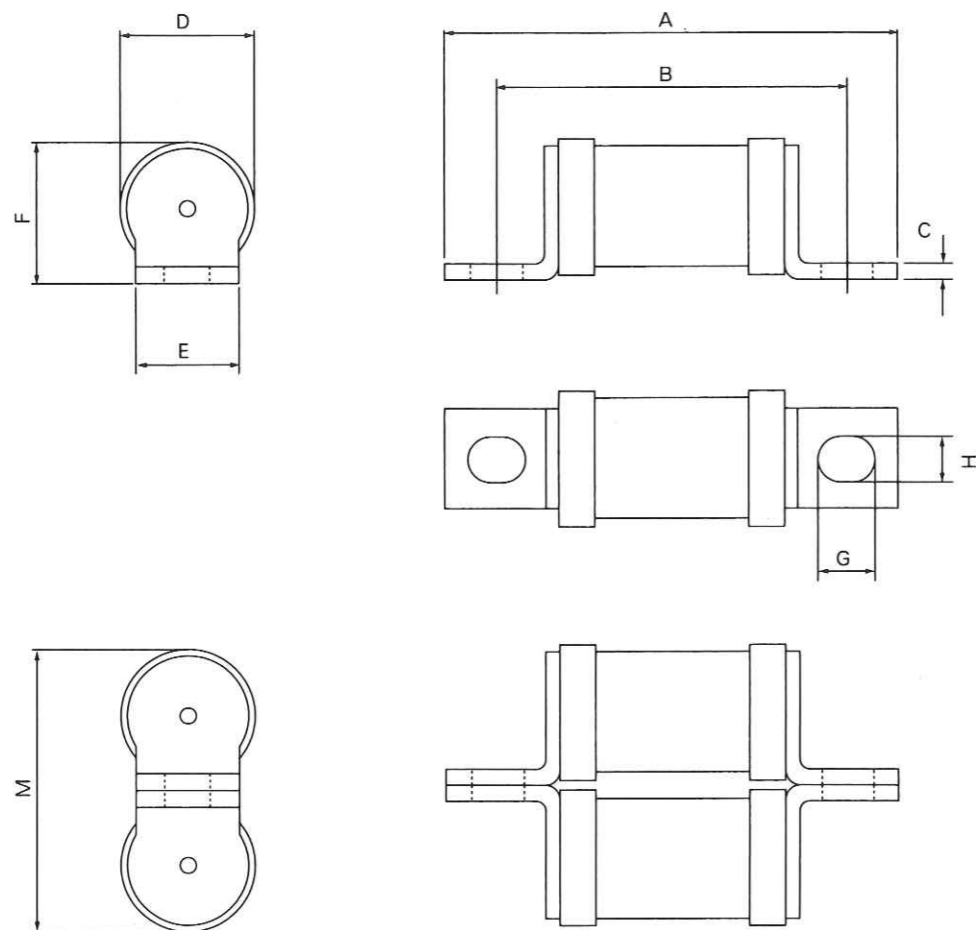

型式 Type	定格電流 Rated Current A	外形寸法 Outline Dimension (mm)								
		A	B	C	D	E	F	G	H	M
JRS31	10・20・30・40・50・60・75	56	42	2	18.2	12	19.1	8.5	6.5	—
JRS32B	60・80・100・120	58	42	2.5	21.3	15	21.7	11	6.5	—
JRS33	90・120・150・180	80	58	3	26.8	20	27.4	11	9	—
JRS36	150・200・250・300	85	60	3	35.6	25	38.8	16	10.3	—
JRS37	350・400●450・500	86	62	3.5	46.5	32.4	51.5	16	10.3	—
*JRS37	600・700・800・900	86	62	3.5	46.5	32.4	51.5	16	10.3	103
JRS61	10・20・30・40・50・60・75	76	62	2	18.2	12	19.1	8.5	6.5	—
JRS62	60・80・100・120	90	70	2.5	21.3	15	21.7	11	9	—
JRS63	90・120・150・180	90	70	3	26.8	20	27.4	11	9	—
JRS66	150・200・250・300	106	81	3	35.6	25	38.8	16	10.3	—
JRS67	350・400●450・500	106	81	3.5	46.5	32.4	51.5	16	10.3	—
*JRS67	600・700・800・900	106	81	3.5	46.5	32.4	51.5	16	10.3	103

* : ダブル形 * : Double Type

JRS30/60型ヒューズ外形寸法 (表示器つき)

Type JRS30/60 Fuse Outline Dimensions (With Indicator)

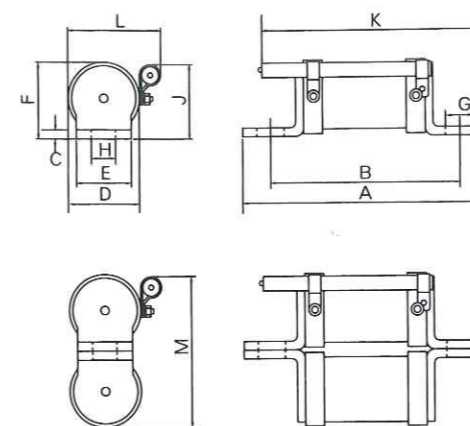

※表示器取付ナットをゆるめる事による表示器位置の調整はできません。
(The position of Indicator is not adjustable.)

型式 Type	外形寸法 Outline Dimension (mm)											
	A	B	C	D	E	F	G	H	J	K	L	M
JRS31	56	42	2	18.2	12	19.1	8.5	6.5	23.8	56.8	27	—
JRS32B	58	42	2.5	21.3	15	21.7	11	6.5	24.8	57.8	30.1	—
JRS33	80	58	3	26.8	20	27.4	11	9	27.8	68.3	35.6	—
JRS36	85	60	3	35.6	25	38.8	16	10.3	34.8	70.2	44.4	—
JRS37	86	62	3.5	46.5	32.4	51.5	16	10.3	42	71.2	55.3	—
*JRS37	86	62	3.5	46.5	32.4	51.5	16	10.3	42	71.2	55.3	93.5
JRS61	76	62	2	18.2	12	19.1	8.5	6.5	23.8	75.8	27	—
JRS62	90	70	2.5	21.3	15	21.7	11	9	24.8	81.8	30.1	—
JRS63	90	70	3	26.8	20	27.4	11	9	27.8	81.8	35.6	—
JRS66	106	81	3	35.6	25	38.8	16	10.3	34.8	90.1	44.4	—
JRS67	106	81	3.5	46.5	32.4	51.5	16	10.3	42	91.1	55.3	—
*JRS67	106	81	3.5	46.5	32.4	51.5	16	10.3	42	91.1	55.3	93.5

* : ダブル形 * : Double Type

JRS30/60型ヒューズ外形寸法 (表示器、マイクロスイッチつき)

Type JRS30/60 Fuse Outline Dimensions (With Indicator and Micro Switch)

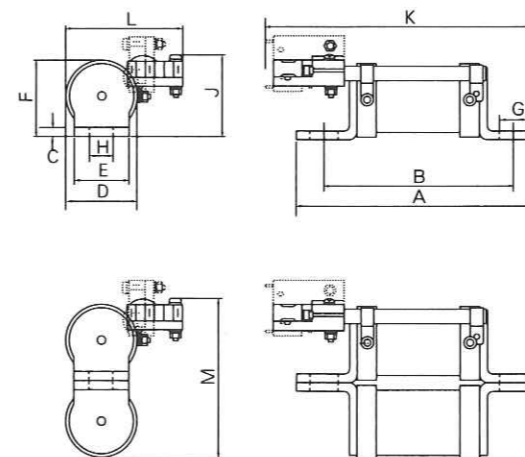

※表示器取付ナットをゆるめる事による表示器位置の調整はできません。
(The position of Indicator is not adjustable.)
※マイクロスイッチは取付ネジをゆるめる事により任意に取外し・位置調整ができます。
(The position of Micro switch is adjustable.)

型式 Type	外形寸法 Outline Dimension (mm)											
	A	B	C	D	E	F	G	H	J	K	L	M
JRS31	56	42	2	18.2	12	19.1	8.5	6.5	25	75	35.4	—
JRS32B	58	42	2.5	21.3	15	21.7	11	6.5	26	76	38.5	—
JRS33	80	58	3	26.8	20	27.4	11	9	29	86.5	44	—
JRS36	85	60	3	35.6	25	38.8	16	10.3	36	88.4	52.8	—
JRS37	86	62	3.5	46.5	32.4	51.5	16	10.3	43.2	89.4	63.7	—
*JRS37	86	62	3.5	46.5	32.4	51.5	16	10.3	43.2	89.4	63.7	94.7
JRS61	76	62	2	18.2	12	19.1	8.5	6.5	25	94	35.4	—
JRS62	90	70	2.5	21.3	15	21.7	11	9	26	100	38.5	—
JRS63	90	70	3	26.8	20	27.4	11	9	29	100	44	—
JRS66	106	81	3	35.6	25	38.8	16	10.3	36	108.3	52.8	—
JRS67	106	81	3.5	46.5	32.4	51.5	16	10.3	43.2	109.3	63.7	—
*JRS67	106	81	3.5	46.5	32.4	51.5	16	10.3	43.2	109.3	63.7	94.7

* : ダブル形 * : Double Type